



A Member of

AAADM

American Association of Automatic Door Manufacturers

AUTOMATIC FOLDING DOOR

OWNER'S MANUAL

Distributed by:



Contents

Section	Page
Caution	2
To Our Customers	2
Service Availability	2
Compliance with Safety Standards	2
What You Should Know	3
Folding Door Configurations & Requirements	3
Daily Safety Check	4 thru 5
General Safety	5 thru 7
Limited Warranty	8



CAUTION

- Failure to follow instructions can result in an improperly adjusted door and can, consequently, cause injury and damage to equipment and property.
- Inspect door operation daily using the “Daily Safety Check” of this Owner’s Manual and at door. Safety devices should be in place and operational.
- Should the door fail to operate as prescribed in the “Daily Safety Check” of this Owner’s Manual or if a potentially hazardous situation is suspected, the door should be taken out of automatic service until a professional inspection is made and the problem is corrected.
DO NOT ATTEMPT TO REPAIR OR ADJUST THE DOOR YOURSELF.
- Have door and all safety devices inspected at least annually by an ***AAADM*** * certified inspector.

To Our Customers

The purpose of this manual is to familiarize you with your automatic door system. It is essential that you know your system and that you recognize the importance of maintaining your door system in compliance with the industry standards for safety as outlined in the ANSI A156.10 - 1999 American National Standard for Power Operated Pedestrian Doors. Your local Horton Automatics service representative will be familiar with the aforementioned standards, as well as all applicable local codes and Horton Automatics recommendations for power operated pedestrian doors. Maintenance and adjustments performed by this service representative/technician will ensure safe and proper operation of the automatic door unit.

Service Availability

Horton Automatics’ products are manufactured at the plant’s facilities in Corpus Christi, Texas and Telford, England. A worldwide network of authorized independent distributors offers both installation and service. For the Horton Automatics distributor in your area call 1-800-531-3111 or consult the Yellow Pages of your local telephone directory under “Door-Operating Devices.” In Europe, call the plant in Telford, England at 011-44-1952-670169.

Compliance with Safety Standards

Your door system was designed to the latest operating and safety standards. In addition to the above recommendations and to ensure the continued safe operation of your door, it is important that proper decals and labels be applied and maintained on your doors (see page 6 of this owners manual for specific decal instruction). If decals are removed or cannot be read, request labels to be replaced when calling for service.

NOTE:** ***AAADM, the American Association of Automatic Door Manufacturers, has established a program to certify automatic door inspectors. Through this program, the inspectors are trained to check the door systems for compliance with the appropriate version of the American National Standards Institute standard A156.10.

What You Should Know

Your local Horton Automatics distributor should provide you with the following for each door after installation:

1. Instructions on how to conduct the “Daily Safety Check” by walk-through example

NOTE: **AAADM** Daily Safety Check videos are available.
Contact your local distributor or **AAADM**.

2. Location of “Automatic/Off/Hold-Open” Rocker Switch.
3. Locations and use of Circuit Breakers.
4. Discussion of problems that could result from door being allowed to operate after a malfunction is observed.

NOTE: If there are any problems, **discontinue door operation immediately** and secure in a safe manner. Call your local distributor for repair.

5. **AAADM** compliance certificate signed by an **AAADM** certified automatic door inspector.
6. This *M-Fold* Owners Manual with the following items filled in:

_____ Phone number to call regarding problems or request for service

_____ Date equipment shipped from Horton plant

_____ Date equipment placed in service

_____ Horton Automatics’ invoice number for Warranty reference and repairs

_____ Equipment type (door series) & Accessories _____

Folding Door Configurations and Requirements

Folding doors are installed in a large number of combinations:

- Doors Fold In (LH, RH) or Doors Fold Out (LHR, RHR)
NOTE: Emergency Breakout standard for both.
- Single Folding Door (LH, RH, LHR, RHR) or Pair of Folding Doors (LH-RH, LHR-RHR)
- One-Way Traffic or Two-Way Traffic
- Activated by Floor Mat, Sensors, or Push Switches

Regardless of the door configuration, the following safety items are always required:

- A Safety Zone (sensors, mats) to cover the area of door travel.
- Guide rails on the fold side of the doors (unless a wall is in the same position)

This manual presents a broad view of the most popular types. It covers the basic principles to check your doors for safety. For questions, call your local service representative.

Daily Safety Check

It is the responsibility of the owner or caretaker of the equipment to perform the following safety checks each day and after any loss of electrical power (perform these tests while traffic is restricted from all detection and sensing zones):

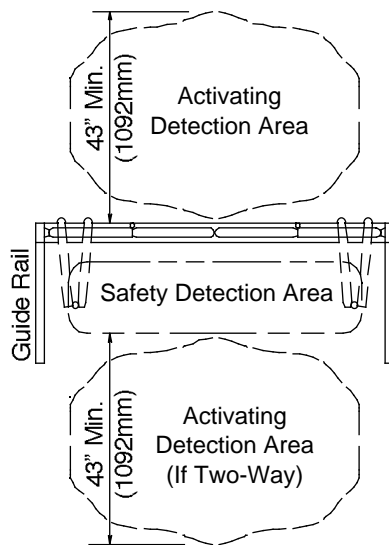

Figure 1

Sensor Activation/Presence Detection Safety

1. Check electronic sensor by walking toward the door at a moderate speed. When about 4' (1219mm) from the opening, it should smoothly start folding open and then stop without impact. Move slowly through the door at 6" (152mm) per sec. The door should remain open.
2. Step out of the sensor zone. After a brief delay (at least 1.5 sec.) the door should close to no less than 2" (51mm) from fully closed, then noticeably slow down and take at least 1.5 sec. for the final 2" (51mm) of closing.
3. Stand in the safety area with door closed, then have someone approach the activating side (see **Figure 1**). It should not open.*
4. Crouch motionless in the door for at least 4 seconds. The door should not close.

Floor Mat Activation/Floor Mat Safety

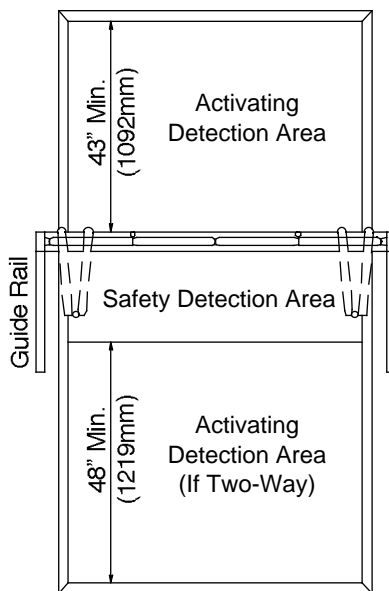

Figure 2

1. Step on the "opening" (activating) mat
2. You must have a safety mat covering the entire fold travel area. Step through the doorway onto the safety mat and remain motionless for 4 sec. The door should stay open. Repeat at several locations on the mat (see **Figure 2**).
3. Step off the safety mat. After a brief delay (at least 1.5 sec.) the door should close to min. 2" (51mm) from fully closed, then noticeably slow down and take at least 1.5 sec. for the final 2" (51mm) of closing.
4. With door closed, step on safety mat on fold side. Have someone step on opening mat. Door should remain closed as long as someone remains on safety mat.*
5. Check the mat molding and threshold. It should be complete and secured with all required screws.
6. Crouch motionless in the door for at least 4 sec. The door should not close.
7. **Do not** move heavy objects over floor mat.

***CAUTION: If safety sensor/mat is not working, door may open toward you without stopping.**

Daily Safety Check (cont.)

Figure 3

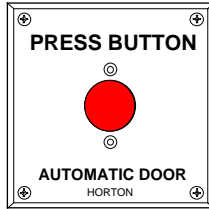

Pushbutton Switch

1" Dia. Red Pushbutton microswitch in 4" sq. X 1 1/2" deep Junction Box assy. mounted on door unit or wall



Front View

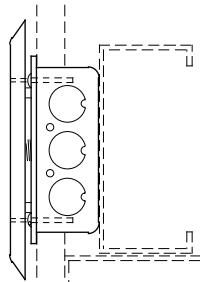

Side View

Push Plate Wall Switch

6 1/4" Dia. Stainless Steel Plate with microswitch assy. in standard Junction Box

Activating Switch (Knowing Act) Safety -

1. Activate door with manual operating switch (see **Figure 3**), then release. Door should hold open for 5 seconds min. after release of activating switch.
2. Reactivate door and crouch motionless in door opening for 10 seconds. Door should not close.

CAUTION

Regardless of the method of activation, if you have a problem, turn off the door operating equipment and call your service representative.

General Safety

1. **Breakout Stop** - Your folding door unit is supplied with an emergency breakout switch that cuts off power to the operator when the door is pushed into the breakout mode. Check that door does not activate.
2. **Lock Stile** - With door open, grasp lock stile of door and attempt to move vertically and horizontally. There should be no looseness in the door pivots or in connections between door and operator. Check periodically.
3. **Housekeeping** - Inspect door's overall appearance:
 - A. Check the threshold area so that it is clean and clear of loose debris or anything else that could create a tripping or slipping hazard.
 - B. Check all door panels (rails, hardware, decals, glass) for damage.
 - C. Make sure that all covers are properly secured.
 - D. There should be no bulletin boards, literature racks, merchandise displays, or other attractions in the door area that would interfere with use of the door. Keep traffic path clear.
4. **Traffic Patterns** - Observe traffic patterns. Plan routing so people enter and exit in a straight approach, directly onto the center of the door opening.
5. **Finger Guard** - Inspect finger guard to see that it is secure and in good repair.

General Safety (cont.)

6. **Decals** - Safety decals play an important role in providing the user with safety signage as outlined in ANSI A156.10. Installer to adhere these decals to the door as instructed and illustrated in **Figure 4**. Call your local distributor to replace any damaged decals.

A. **One-Way Traffic** - Visible from non-approach side: "DO NOT ENTER" in white letters on red background. Visible from approach side: Arrow Sign - to have green circle surrounding black arrow on white background.

B. **Two-Way Traffic** - Visible from both sides of the door with the words "CAUTION, AUTOMATIC DOOR". The words "Automatic Door" must be in black lettering on yellow background and be at least 1/2" (6mm) tall.

NOTE: Minimum diameter of circular decals should be 6" (152mm).

C. **Manual Activation Switch (Knowing Act)** - Visible from both sides of the door with the words "Automatic Door. Activate Switch to Operate."

D. **AAADM** safety information sticker (Daily Safety Check) should be affixed on the door frame in a protected, visible location. A separate sticker, confirming compliance and showing date of inspection, should be affixed by certified **AAADM** inspector just below Daily Safety Check.

Figure 4

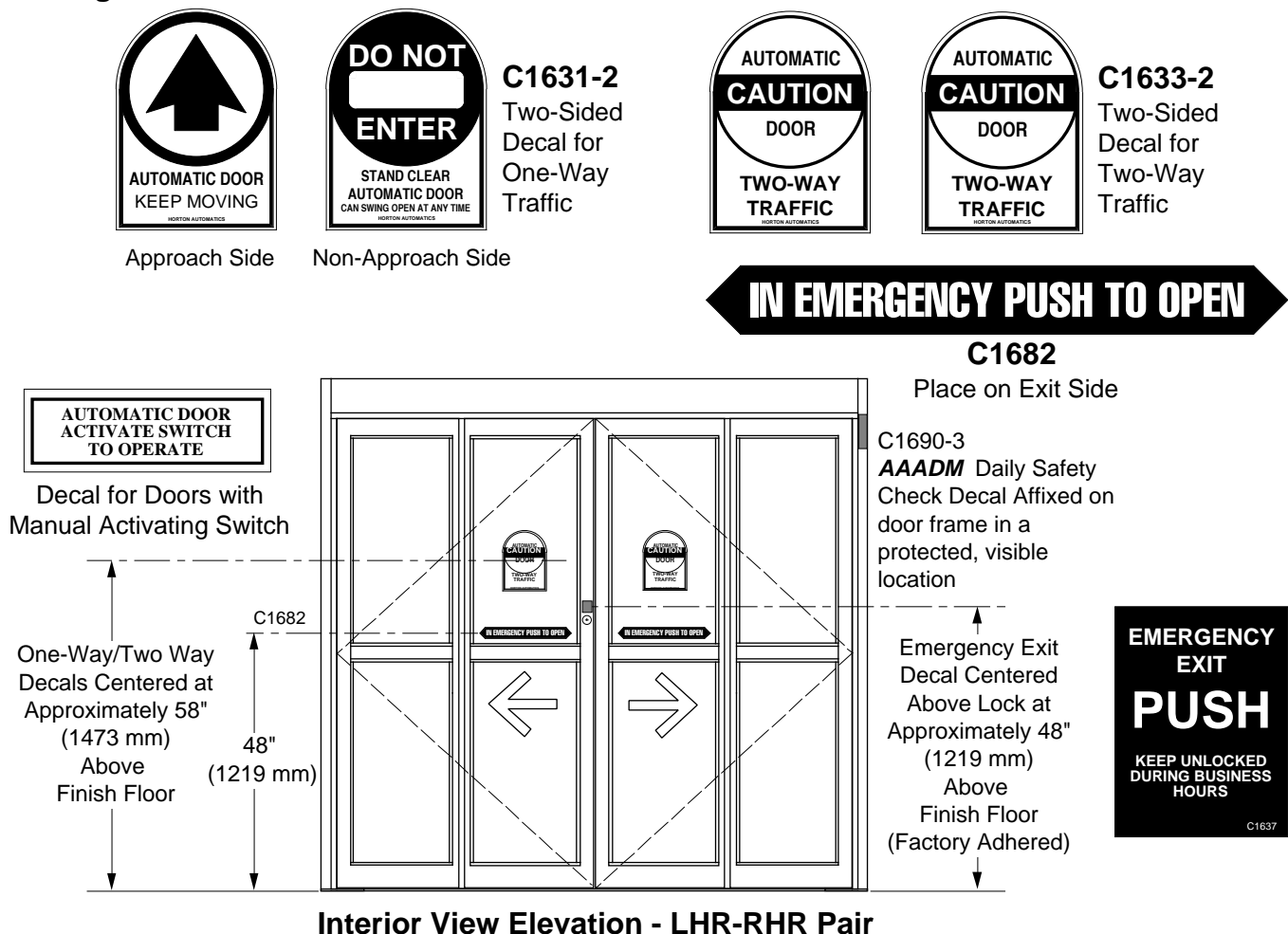

General Safety (cont.)

7. **Guide Rails** - Check that guide rails or other barriers or separators are present (one per unit side) and firmly anchored (see **Figure 5**). Check guide rail size (see **Figures 6 & 7**).

Figure 5

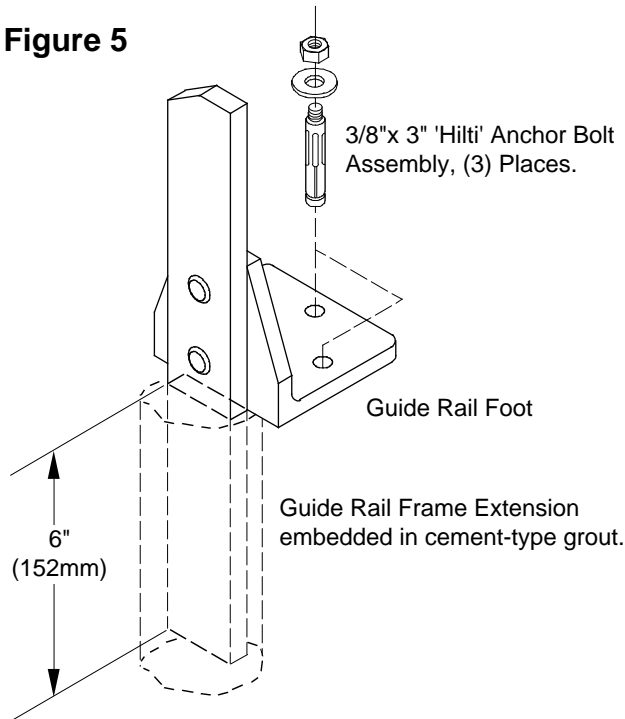

Guide Rail Anchorage to Floor

"A" = 12" (305 mm)
for two-way traffic or one-way with approach side from fold side.
OR
"A" = 5" (217 mm)
for one-way traffic with approach from non-fold side.

Figure 6

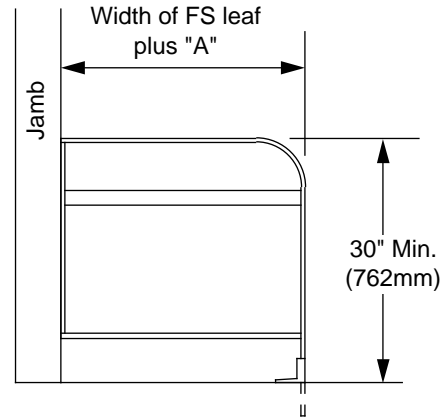

Jamb and Floor Mounted

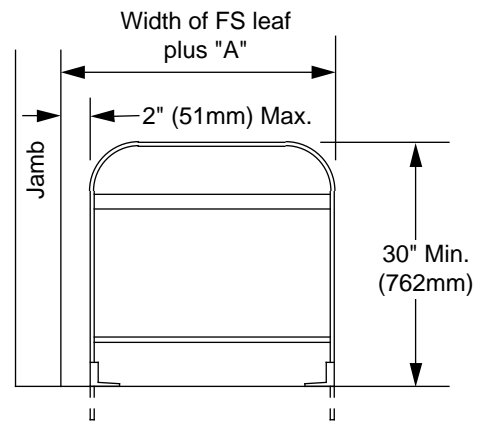

Free Standing Floor Mounted

Figure 7

Pair of Bifold Doors

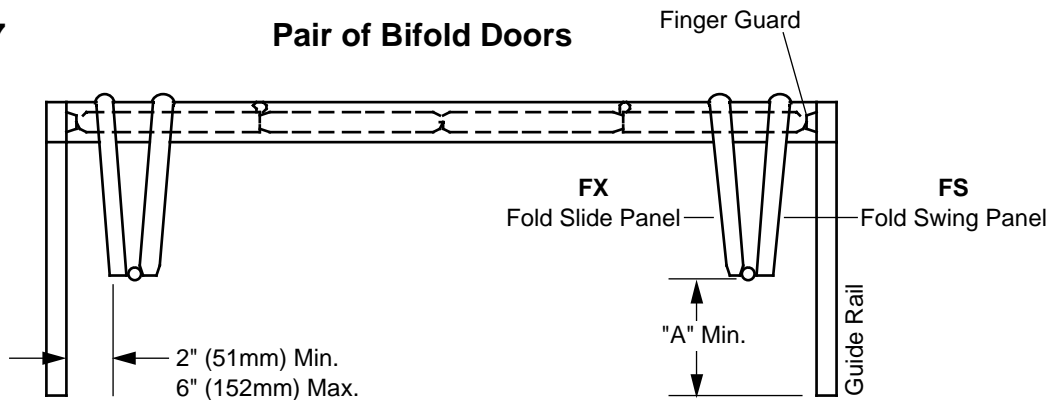

Limited Warranty

Horton Automatics (Seller) warrants to the Buyer all products they manufacture to be free from defects in material and workmanship, under normal use and service, for twelve months from the date product is placed in operation. The Seller's obligation under this warranty is limited to the repair or replacement at the factory, of any parts which shall be returned to the Seller with transportation charges prepaid and which after examination, prove to be defective. Said warranty shall not apply to such products which shall have been installed, altered, or repaired by any person not expressly authorized in writing for such purpose by the Seller, or subjected to misuse, negligence or accident. The aforesaid warranty is made expressly in lieu of other warranties, expressed or implied and in lieu of any other obligations or liabilities on the part of the Seller and the Seller neither assumes nor authorizes any person to assume for it any other liability or obligations in connection with the sale of such products to the Buyer.

There is no warranty of merchantability or fitness for any particular purpose, nor is there any warranty, expressed or implied, except as specifically stated above. seller shall not be liable for special or consequential damage, nor for claims of any third party against the buyer.

Generally, the installing distributor provides a one-year warranty covering the labor and transportation charges for defective parts replacement. If this is the customer's wish, it should be specified.



4242 Baldwin Boulevard
Corpus Christi, Texas 78405-3399
Tel: 361-888-5591
Fax: 361-888-6510
Toll Free in North America:
Tel: 1-800-531-3111
Fax: 1-800-531-3108
Internet:<http://www.hortondoors.com>

Horton Automatics, Ltd.
Unit A, Hortonwood 31
Telford, Shropshire
England TFI-7YZ
Tel: 01952 670169
Fax: 01952 670181
International Numbers:
Tel: ++44-1952-670169
Fax: ++44-1952-670181